

Operation of *Titanic's* Engelhardt Collapsible Lifeboats

By Bob Read, D.M.D.

Introduction

Very little is commonly known among most *Titanic* enthusiasts about how exactly *Titanic's* Engelhardt collapsible boats actually operated. This article will explain the operation of the Engelhardt boats.

Structure

Technically *Titanic's* Engelhardt boats are not “collapsible” boats. The proper designation for *Titanic's* Engelhardt boats is a “decked” boat. The hulls of *Titanic's* Engelhardt boats were very shallow, clinker-built hulls with a deck built over the gunwales. From the bottom of the keel to the deck surface of the boat was only roughly 14 inches. The hull was closer to being a raft than a conventional wooden boat. Not only was the hull sealed by a deck but, the interior of the hull was filled with cork to give buoyancy in the event of a leak. Another measure to provide back-up buoyancy is the installation of cork filled fenders around the gunwales. Being essentially a raft with canvas sides, the hull of the boat couldn't take on water unless the hull was breached.

Dimensions

Figures 1 and 2 show the dimensions of *Titanic's* Engelhardt boat without the bulwarks.

[Go to next page](#)

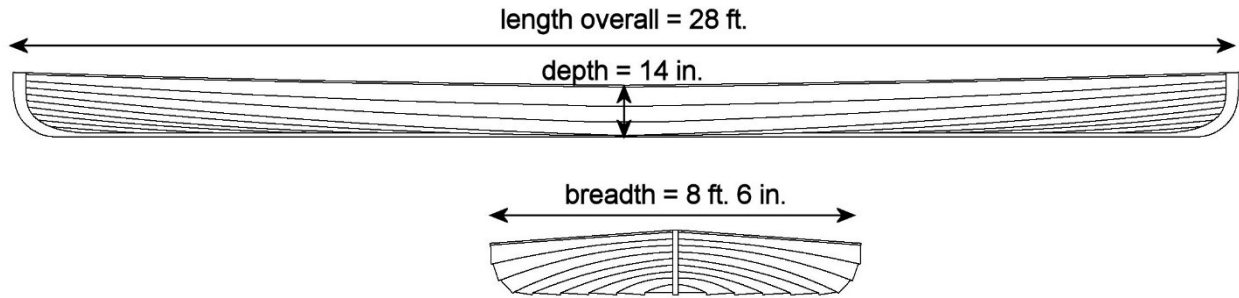

Figure 1

Principal dimensions of *Titanic's* Engelhardt boat wooden hull

The principal dimensions of the wooden hull were: Length overall = 28 ft., Depth = 14 in., Breadth = 8 ft. 6 in.

Bulwarks, Side Benches, and Thwarts

The structures above the deck of the hull consisted of a top rail which was connected to the deck by folding struts. Figures 2 and 3 show the top rail, struts, and lifting beam in both collapsed and raised positions.

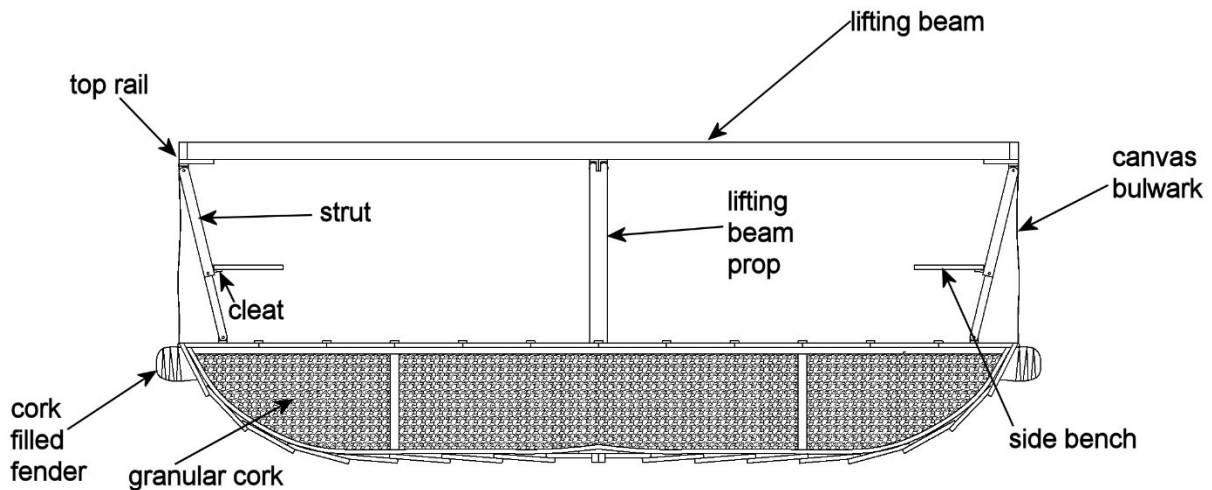

Figure 2

Top rail, struts, and lifting beam in raised position

Go to next page

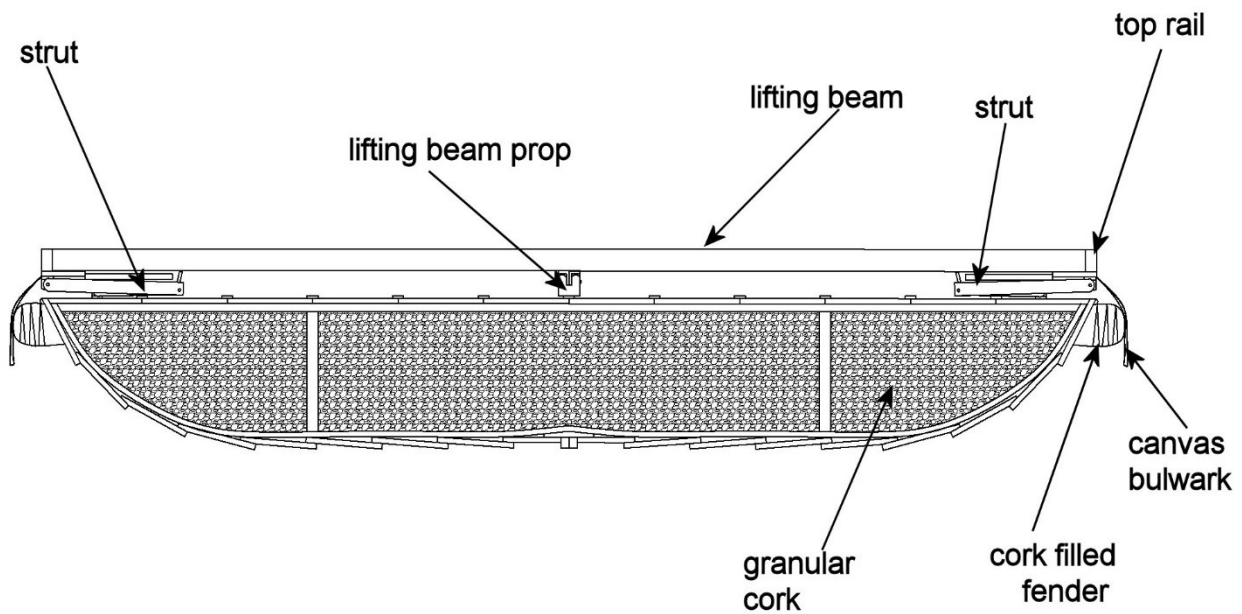

Figure 3

Top rail, struts, and lifting beam in collapsed position

To raise the top rail and canvas bulwarks which were attached to the outer surface of the top rail and the deck, the two lifting beams were raised which unfolded the struts. The struts were two channel section lengths of steel. The lower part of the strut fit inside the upper part when they were collapsed and folded. The upper part of the strut was fastened to the top rail with a hinge. The bottom part of the strut was attached to the deck with another hinge. There was a third hinge between the upper and lower sections of the strut.

The side benches and the thwarts were a one-piece unit. This seat unit was “free-floating” in that it had no attachment to any other structures. When the top rail, lifting beams, and canvas bulwarks are being raised, there are cleats on the inboard surface of the struts which engage and lift the seat unit to the proper height. The weight of the seat unit prevents the struts from collapsing. Also, the lifting beams have hinged props which rotate downward and support the lifting beams at the proper height.

Figures 4 and 5 show the seat unit in its collapsed position then supported by cleats on the struts in its raised position.

Go to next page

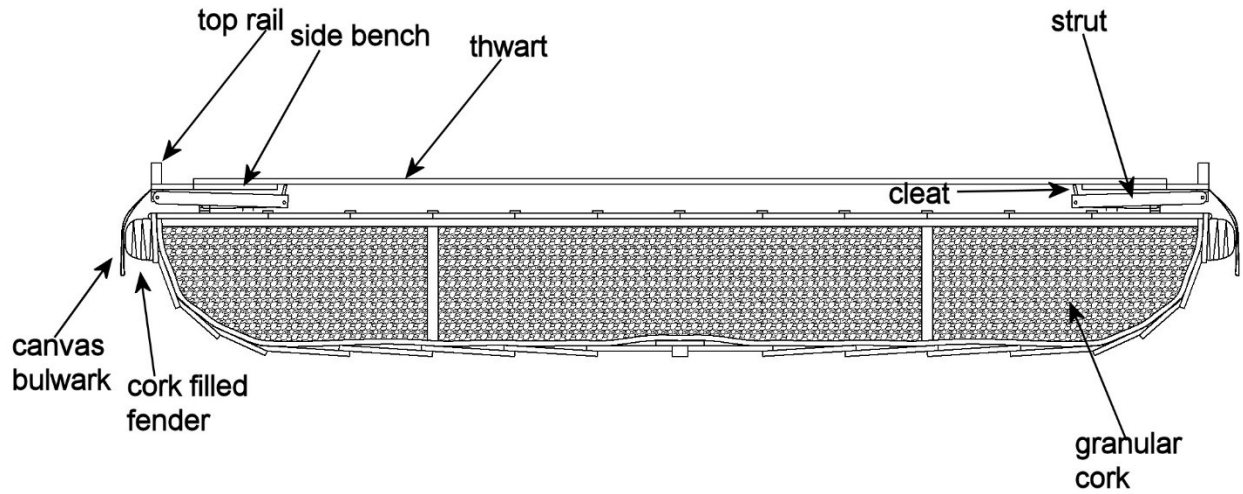

Figure 4

Side benches, thwarts, and bulwarks in collapsed position

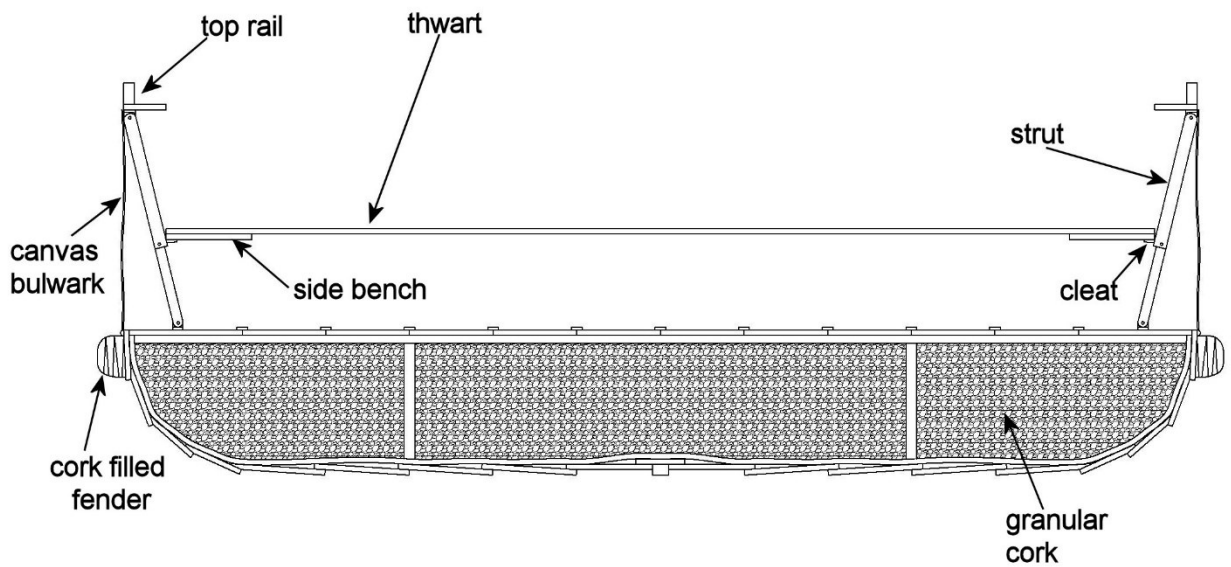

Figure 5

Side benches, thwarts, and bulwarks in raised position

To lower the bulwarks, the seat unit must be lifted slightly to take the weight off the struts. Then the lifting beam props are disengaged and the lifting beam is pushed downward which causes the struts to begin to fold. The seat unit is released and the weight causes the bulwarks, struts, and seat unit to fold down to their lowest collapsed position.

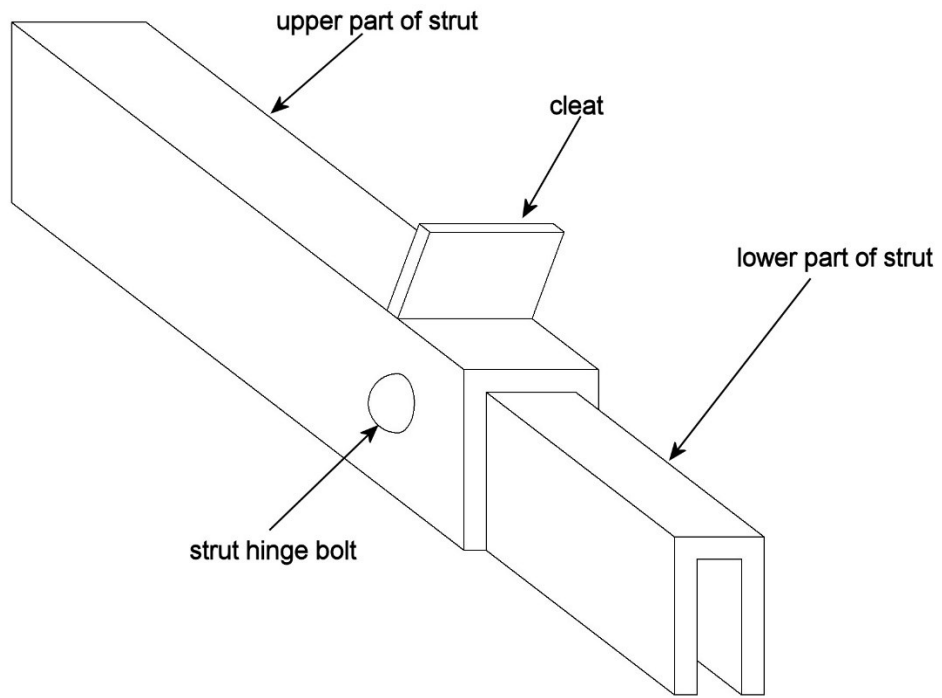

Figure 6

Construction of strut

Figures 2 and 3 are shown in Figure 7 as a section between B-B. Figures 4 and 5 are shown in Figure 6 as a section between A-A.

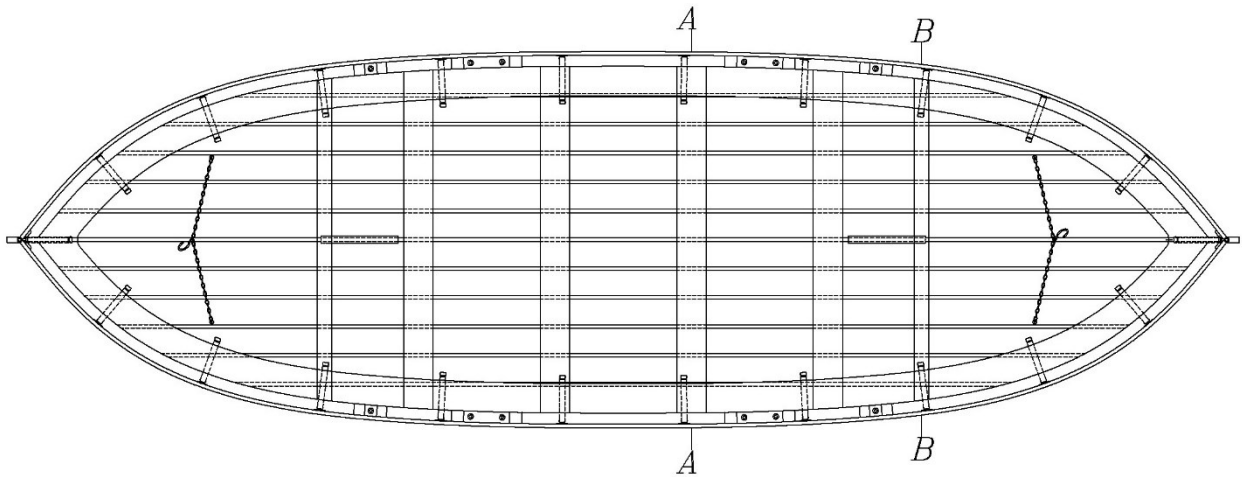

Figure 7

Engelhardt boat in collapsed position showing reference sections A-A and B-B

Operation

After the bulwarks were raised and secured, the boat was loaded with passengers. Hooks at either end of the boat were engaged with the davit falls and the boat was lowered. There were sockets on the top surface of the top rail into which bronze oar crutches were inserted. Oars could then be operated. The boat did not have a rudder so there was a socket in the aft end of the top rail to receive a bronze oar crutch which bore a steering oar.

The boat was equipped with the standard boat equipment like a biscuit tank, water breaker, etc. If the boat was to be recovered, the hoisting hooks inside the boat would be attached to falls and the boat would be brought aboard.

Figure 8 is a photo of one of Titanic's Engelhardt boats which RMS *Oceanic* found.



Figure 8

One of *Titanic's* Engelhardt boats found by RMS *Oceanic*

Go to next page

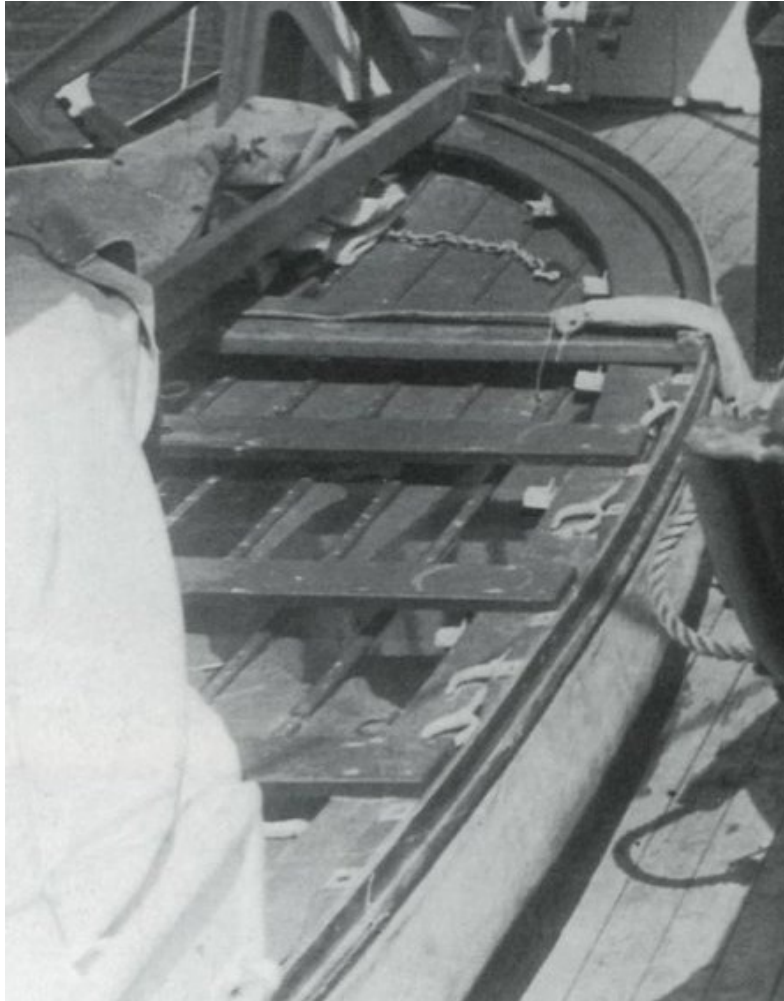

Figure 9

Engelhardt boat aboard RMS *Olympic*

Go to next page



Figure 10

Titanic Engelhardt boat heading for RMS *Carpathia*

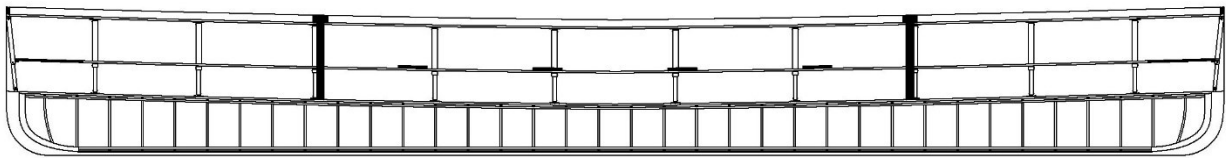

Figure 11

Longitudinal cross section of one of *Titanic's* Engelhardt boats

Summary

This article has been written to explain the details of the Engelhardt collapsible lifeboats found aboard *Titanic*. The basic structure of the boat was explained. Procedures to raise and lower the bulwarks were illustrated. Finally, the launch and recovery procedures were explained.

