

# Wooden Plank Sheathing of *Titanic's* Forecastle Deck

---

By Bob Read, D.M.D.

## Introduction

This article is an updated version of a previous article with the same title. A few modifications have been made to the original article to reflect new discoveries and to correct mistakes.

The layout of wooden deck sheathing of *Titanic's* forecastle deck is rather complex. This article is written primarily for the modeler who wishes to achieve a greater level of accuracy. Individual planks for deck sheathing are really only practical at very large scales such as 1/48 and larger. Even at those scales, a neater effect could be achieved by transferring the pattern onto a wooden deck which is nearly grain free. This article will not discuss modeling techniques but will describe the full-scale practice of laying the sheathing planks. This will not be a discussion of all the procedures for laying wood deck sheathing over a steel deck. Those procedures have been discussed in depth in other publications. Basic terminology will be discussed and detailed drawings of particular areas of interest will be shown and explained.

## Basic Terminology

On steel ships like *Titanic* the decks were steel. They were not visible in most cases because they were "sheathed" with wooden planks. This sheathing gave an even surface which was safer to walk on, provided insulation, and protected the steel deck below it from deterioration. In discussing *Titanic's* forecastle deck, we have two species of wood which were used for the sheathing. Around the perimeter of the deck and around certain structures, teak planking was used. Teak was used because it was the most resistant to rot and therefore was used in applications where it could practically be a lifetime installation with no need for removal of equipment to replace it. The majority of the surface of *Titanic's* forecastle deck was sheathed with pitch pine planking. Pitch pine was more resistant to rot than the yellow pine used on other decks but was not as durable as the teak. It had the advantage of being less expensive.

The term for the rows of planking is a "strake". A strake could be made up of a single plank or of several planks. Where several planks met within a strake is known as a "butt". In examining photos of *Titanic's* forecastle deck, it appears that full length planks were used. The only place where butts are found are where the pitch pine met teak planking. Planking of teak around the perimeter of the deck and around certain deck structures was known as "margin planking".

Figure 1 shows some of the terms discussed above which are labeled. In the drawing the pitch pine planking is not colored. The teak planking is colored blue.

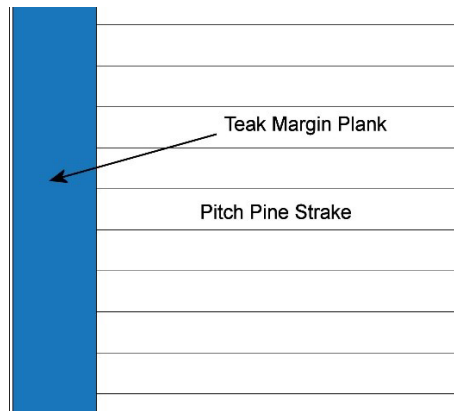

Figure 1

### Plank sheathing terminology

The next term which will be used in this article is “nibbing”. When strakes of the pitch pine planking meet margin planks at certain angles, the ends of the pitch pine planks needed to be “nibbed”. This means that their ends are cut so the plank does not taper to a fine featheredge point. This is done because such finely tapered planks would have a long area on their ends where the plank was not able to be fastened to the deck by bolts. This would cause fracture of the plank ends. Generally, if the tapered part of the plank end is greater than the width of the plank, it needs to be nibbed. To nib the plank, half the width of the plank is measured into the margin plank. From this point, the plank is cut at an angle where it meets the margin plank at its full width. The margin plank is cut to match the nibbed plank.

Figure 2 shows planks meeting a margin plank at an angle. The angle is such that if the planks were cut to the angle of the margin plank there would be a long featheredge on the plank end. If the length of this bevel  $Y$  is measured, it can be seen that it is greater than the width  $X$  of the plank. This means the plank must be nibbed.

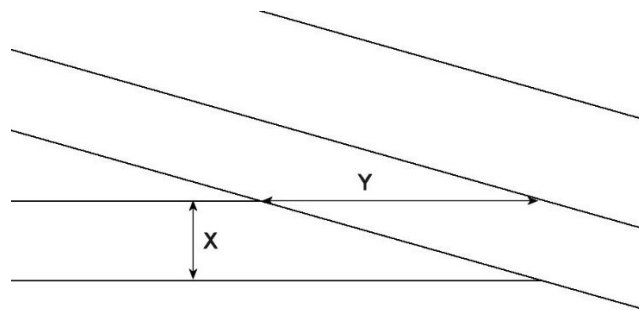

Figure 2

Bevel where pitch pine planking meets margin plank

Figure 3 shows how the plank is nibbed. Where the bottom edge meets the margin plank, a distance one half of the width of the plank is measured perpendicular to the plank. From the end of this line, another line is drawn to the point on the plank where the top edge meets the margin plank at full width. The plank is now cut to these nibbing lines. The plank is then set against the margin plank and the margin plank is cut to match so the nibbed plank fits into it. In this figure you can see that the length of the bevel of the plank is greater than the width of the plank  $X$ , so nibbing is needed. On the outboard edges of *Titanic's* forecastle deck there was a margin plank and inboard of it was a "nibbing strake" also of teak, into which planks were nibbed.

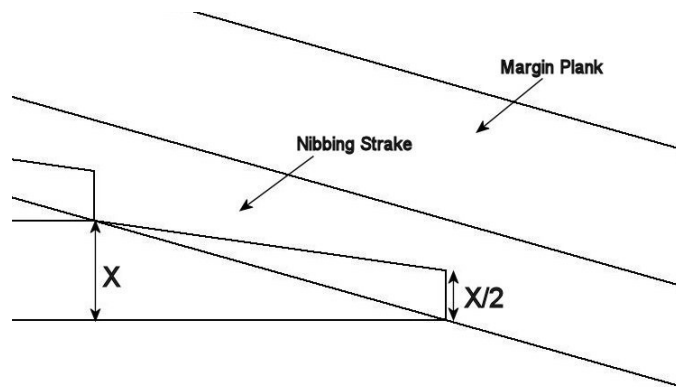

Figure 3

### Procedure for nibbing planks

Figure 4 shows the finished nibbing into the nibbing strake inboard of the margin plank.

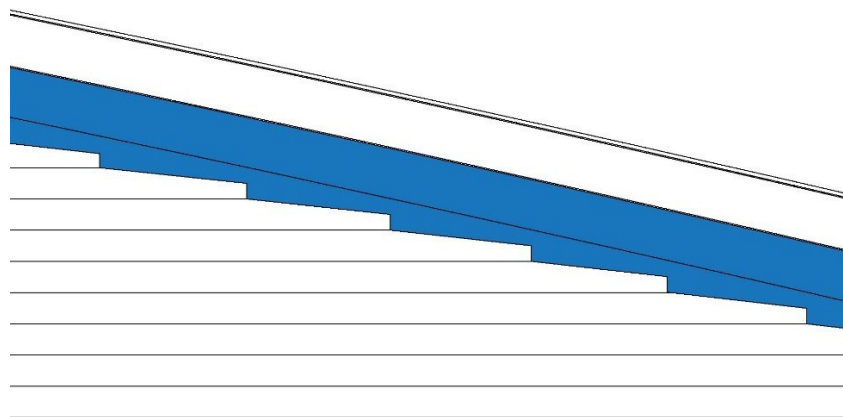

Figure 4

### Planks nibbed

Figure 5 shows an overall view of *Titanic's* forecastle deck sheathing. Individual numbered areas within the red rectangles will be individually discussed.

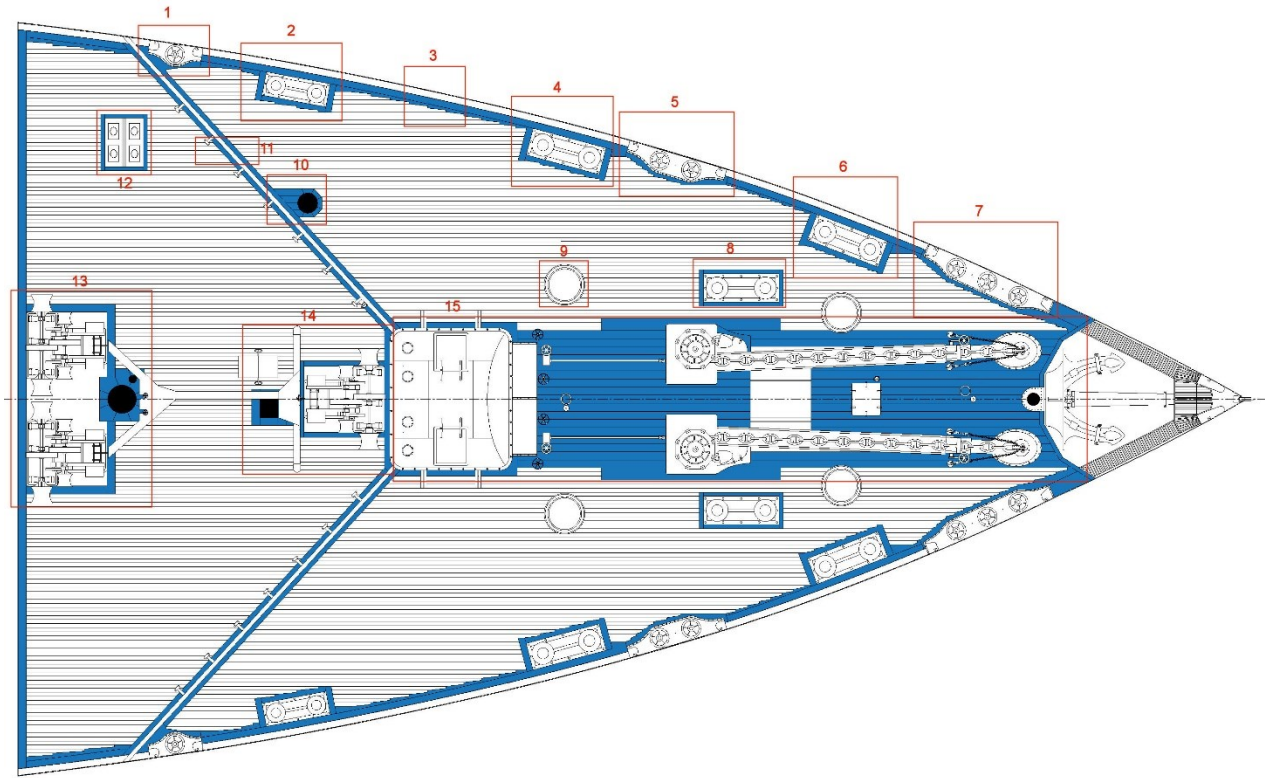

Figure 5

### Overall view of forecastle deck planking

Figure 6 shows the planking around the single roller fairlead just forward of the breakwater. The roller fairleads sat directly atop the teak margin planking and were riveted through the steel deck below. The outboard edge sat over the steel channel section waterway.

Go to next page

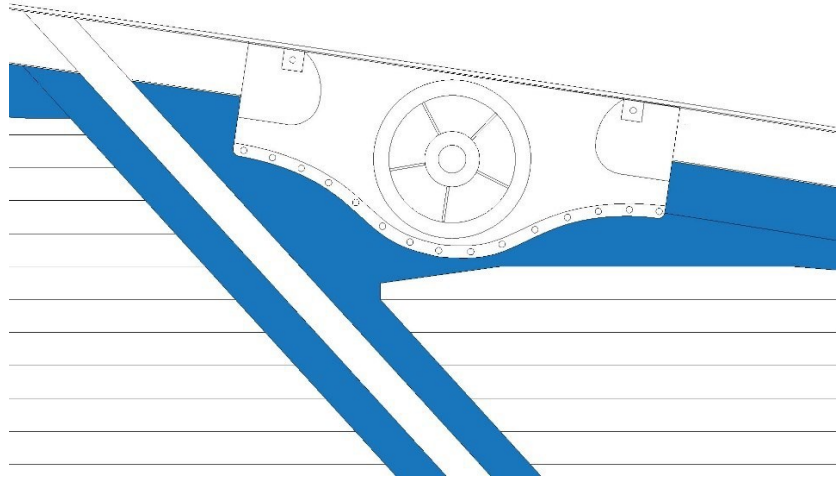

Figure 6

Area #1

Figure 7 shows the area around the aftmost bollard. The bollards were riveted directly to the steel deck. Therefore, a teak margin plank had to be fitted around it. This drawing shows the margin planks around the bollard and the nibbing of the pitch pine planks into it.

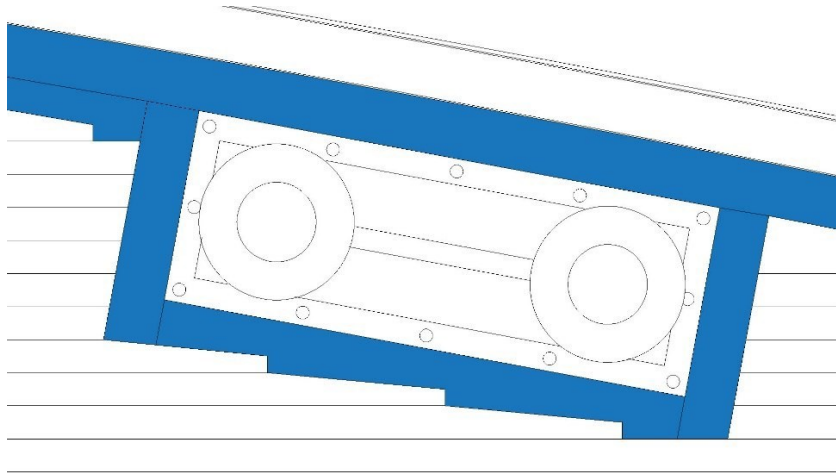

Figure 7

Area #2

Go to next page

Figure 8 shows the nibbing of the pitch pine planks into the margin plank around a forecastle bollard on *Olympic*.



Figure 8

### Deck sheathing around forecastle bollard

Figure 9 shows the nibbing of the pitch pine planks into the teak margin plank which is inboard of the channel section waterway.

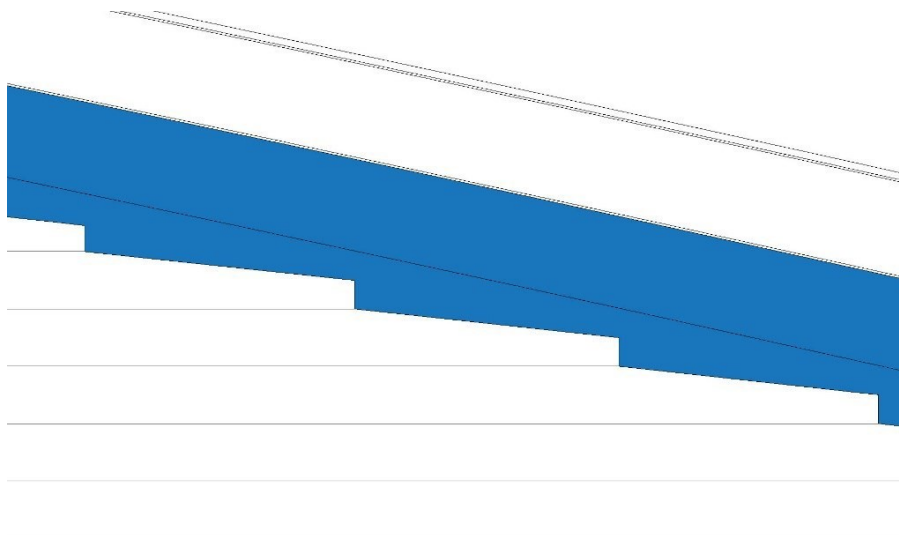

Figure 9

Area #3

Figure 10 shows the middle bollard just aft of the double roller fairlead and teak margin planking and the pitch pine planking nibbed into it.

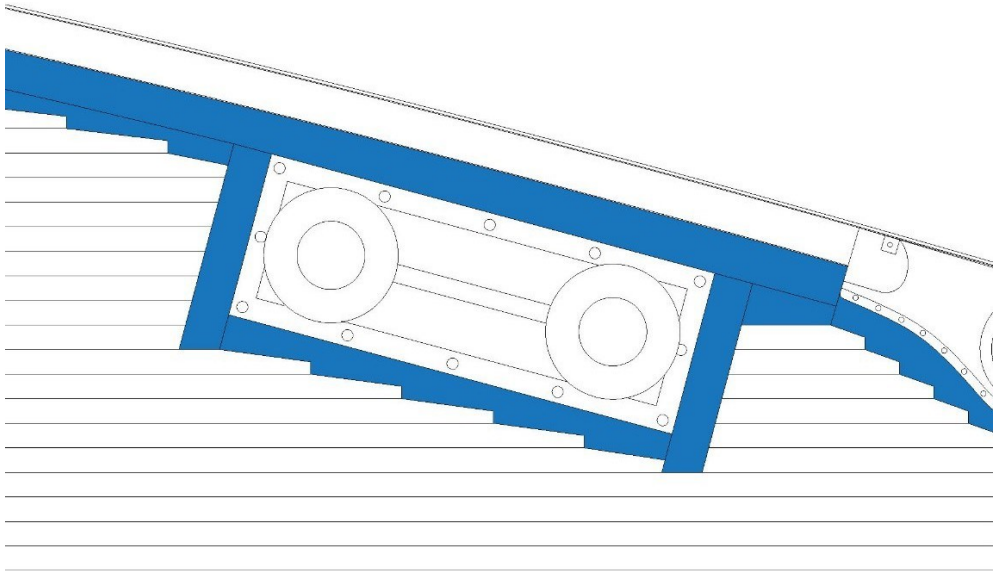

Figure 10

Area #4

Figure 11 shows the teak margin planking and pitch pine planking around the double fairlead.

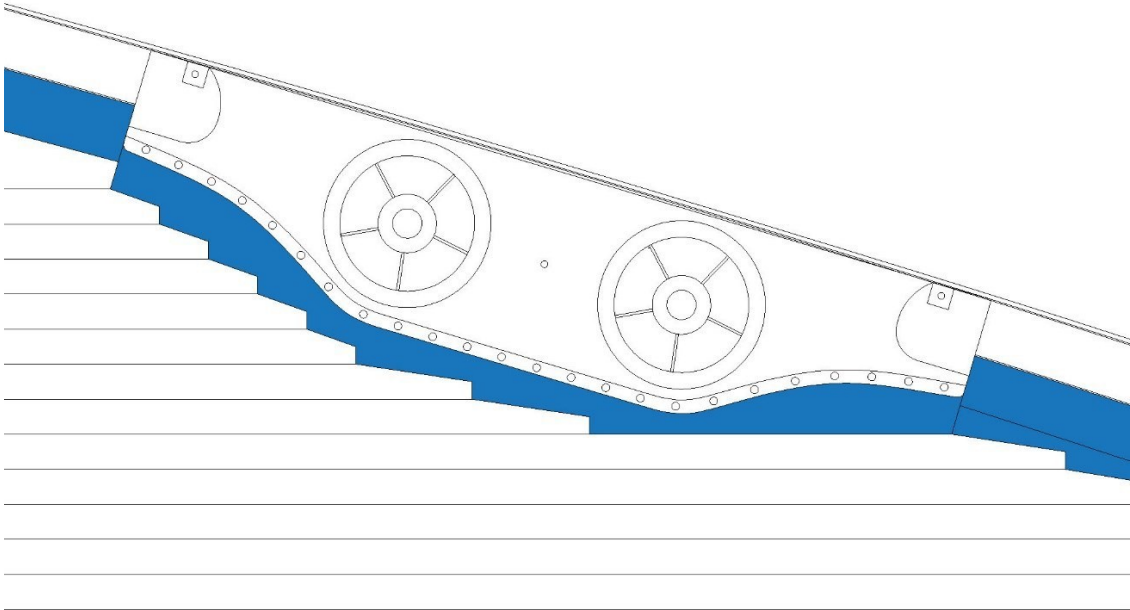

Figure 11

Area #5

Figure 12 shows the teak margin planking and the pitch pine planking around the forward bollard.

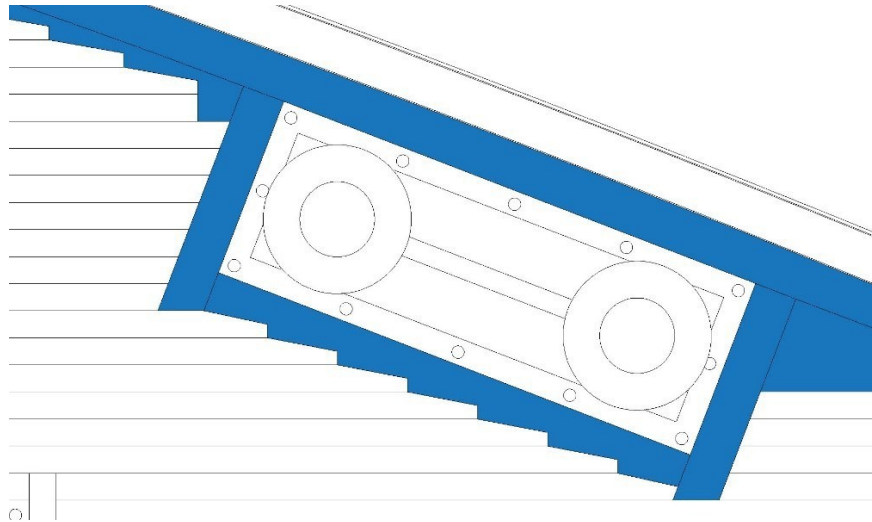

Figure 12

Area #6

Figure 13 shows the treble roller fairlead. The waterway terminates just aft of the fairlead. The fairlead sits completely atop the margin planking.

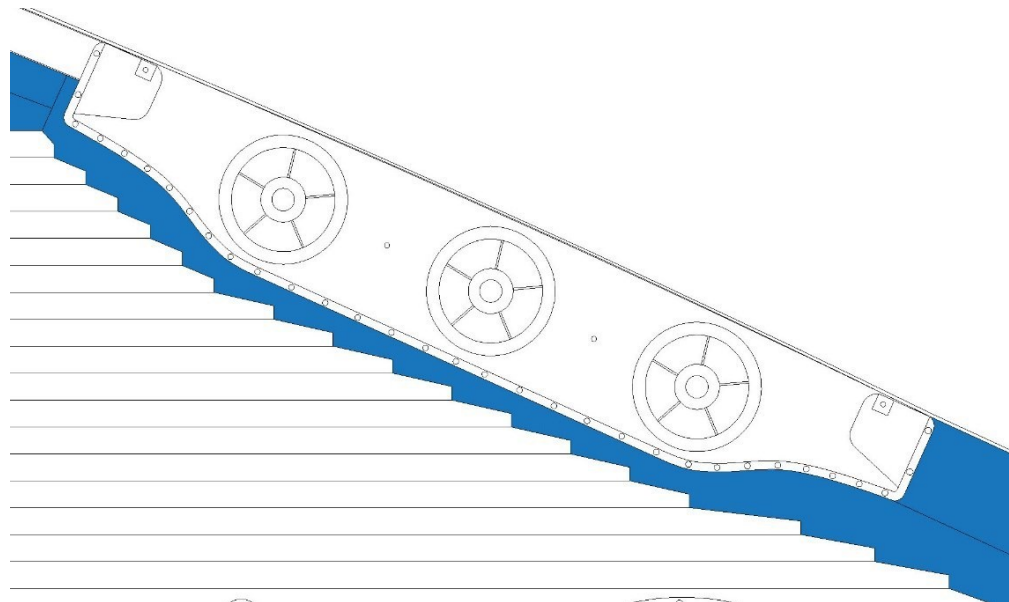

Figure 13

Area #7



Figure 14 shows an Olympic photo of the nibbing of pitch pine planks around the treble fairlead.



Figure14

### Planking around treble fairlead

Figure 15 shows the inboard bollard which sits fore and aft parallel to the midline. No nibbing is necessary into the teak margin planks around this bollard.

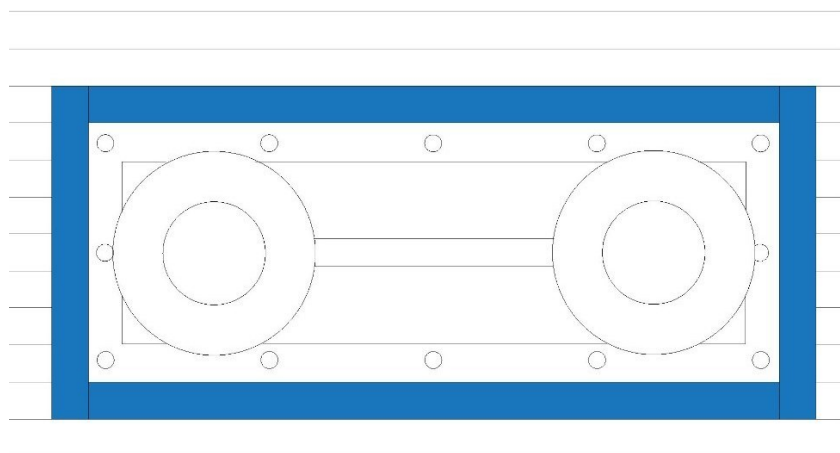

Figure 15

Area #8

Figure 16 shows a rear capstan. The capstans had lower flanges that fit on top of the surrounding pitch pine planking. They did not require teak margin planking around them.

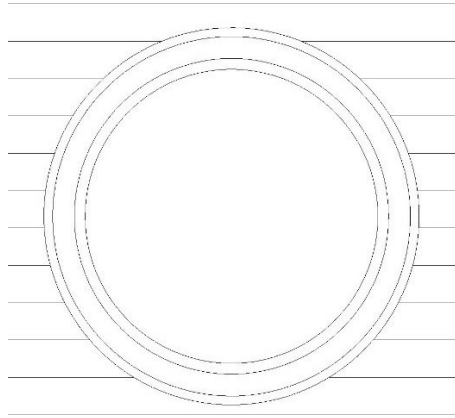

Figure 16

Area #9

Figure 17 shows the lack of margin planking around a capstan of *Olympic's* forecastle.



Figure 17

Pitch pine planking around capstan

Figure 18 shows the margin planking around the base of the cowl vent on the port side just forward of the breakwater.

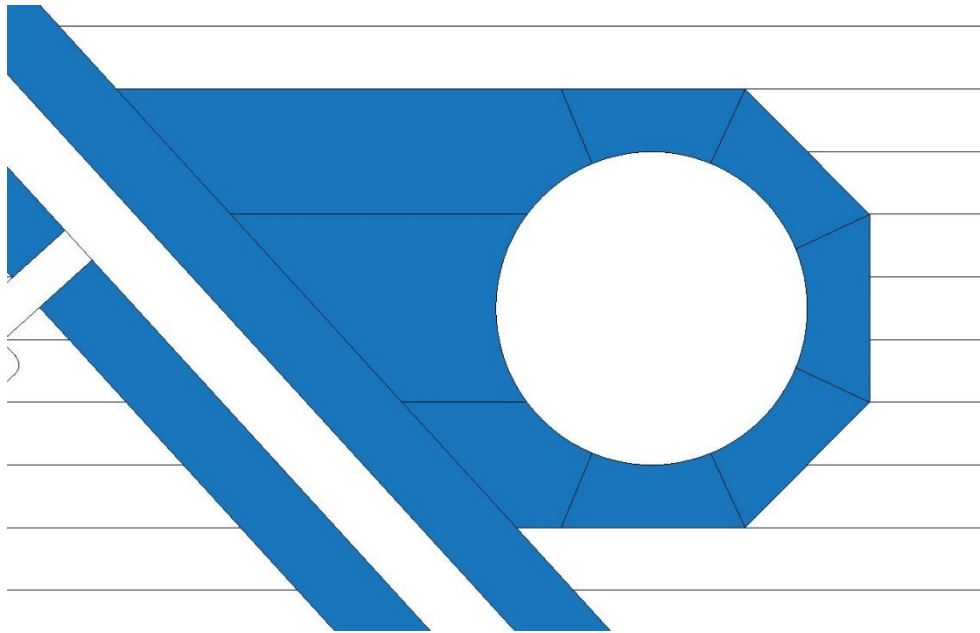

Figure 18

Area #10

Figure 19 shows the teak margin planking fore and aft of the breakwater. The breakwater stays on the aft side of the breakwater are bolted through the pitch pine planks.

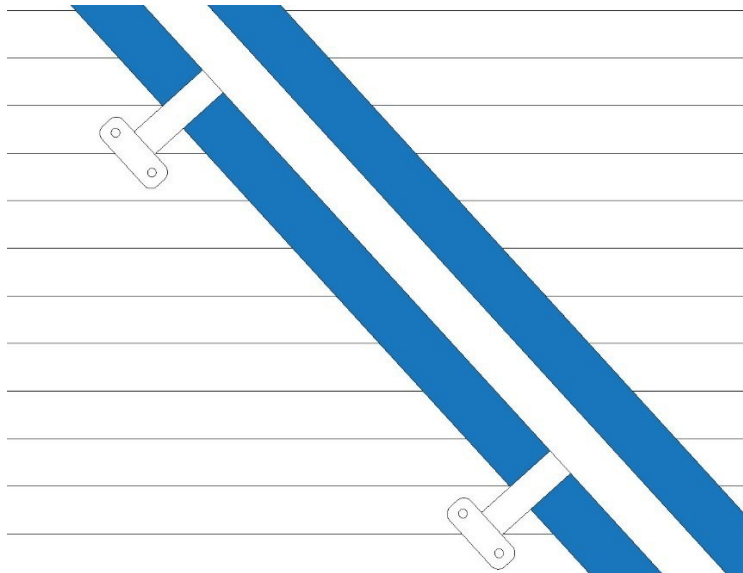

Figure 19

Area #11

Figure 20 shows the margin planking on the aft side of *Olympic's* breakwater.



Figure 20

### Planking on the aft side of *Olympic's* breakwater

Figure 21 shows the margin planking around the skylight on the port aft of the forecastle. The skylight sits square with the run of the pitch pine planking so no nibbing is required.

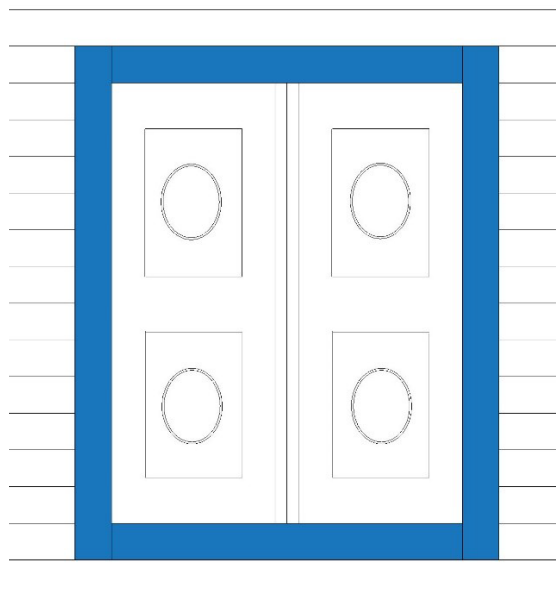

Figure 21

Area #12

Figure 22 shows the margin planking around the steam winches at the aft of the forecastle deck. The winches sit atop a cement base which is first poured inside the margin planks which form the perimeter of the cement base.

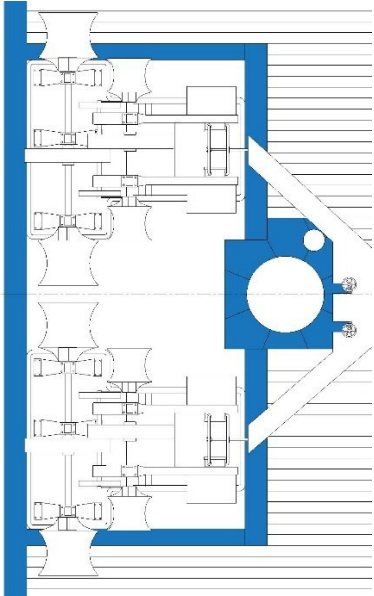

Figure 22

Area #13

Figure 23 shows the margin planking around the forward steam winch and the ventilator duct on the starboard side of the steam pipe cover.

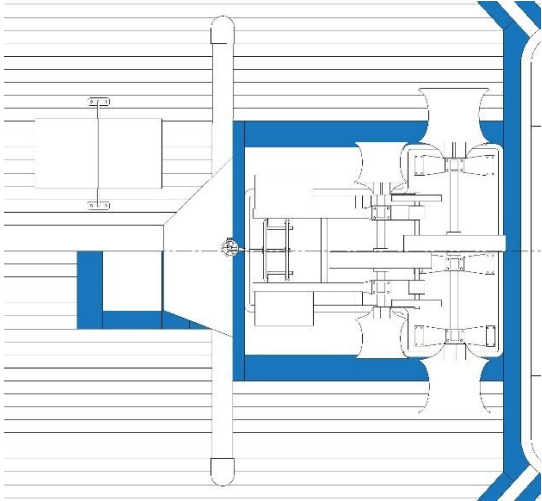

Figure 23

Area #14

Figure 24 shows the absence of any margin planking under the lateral steam pipe cover branch on the port side of the midline of *Olympic*.



Figure 24

Pitch pine planking under steam pipe cover

Area #15 shown in Figure 25 encompasses the area from the #1 cargo hatch forward to the forward anchor well. This area is unique in that there is teak planking in this entire area. The planks here are 10 inches wide by 4 inches thick. There are two planks outboard of the windlasses which are 15 inches wide by 4 inches thick. These are the only exceptions. Where the thicker central teak planking meets the thinner 3-inch-thick pitch pine planking, the thicker teak planking is planed so there is a smooth transition as can be seen aboard RMS *Oceanic* in Figure 26. There is photo evidence on *Olympic* which confirms this smooth transition. Forward, the anchor well has a teak margin plank on its aft side.

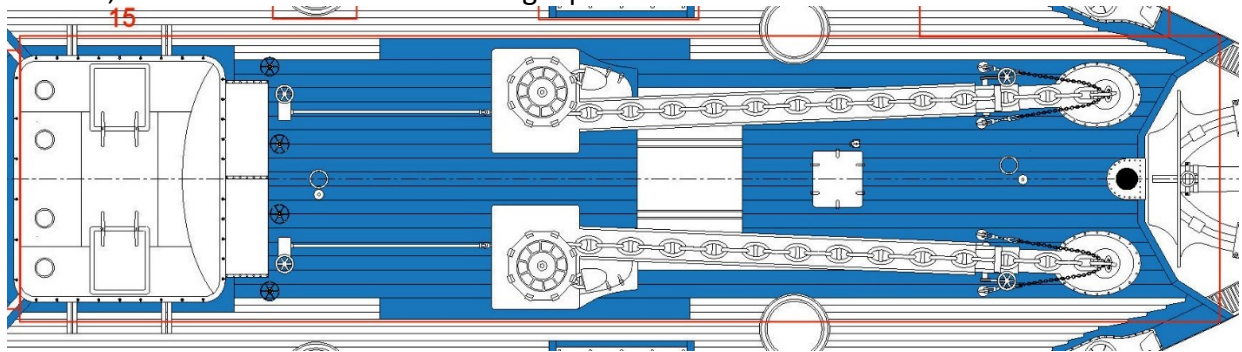

Figure 25

Area #15



Figure 26

Smooth transition between teak and pitch pine planking on *Oceanic*

### Color

In the previous version of this article I portrayed the pitch pine and teak as two very different colors so there wouldn't be any confusion which was which. Unfortunately, I started seeing models with the teak portrayed as a reddish wood almost like redwood with a pronounced contrast between it and the pitch pine. Figure 27 shows three examples of not overly weathered teak, pitch pine and yellow pine.



Figure 27

Comparison of colors of wood species used on Titanic

As soon as even mild weathering occurred on these different types of wood, the color differences would become even less noticeable.

## Conclusion

The layout of deck sheathing planks on *Titanic's* forecastle is more complex than any other area of the ship due to the number of pieces of deck equipment and the necessity of providing a surface which would be resistant to rot due to the constant wetting of this deck.

Representative areas of the deck were examined in detail to show the layout of teak margin planking and pitch pine planking. Photos were used where possible to confirm the layout but where photos were not available, planking rules used in other areas were applied. This article will provide guidance to the modeler and general information to the historian.