

# Deployment of Titanic's Kedge Anchor

---

Titanic and Olympic were equipped with two auxiliary anchors. Both of these anchors were the Trotman patent anchor type. The larger, one ton anchor was located on the starboard aft forecastle and was designated as a "stream" anchor. The other was a ½ ton anchor located against the aft poop deck railing and was designated a "kedge" anchor. The reference which specifies the type and locations of these two anchors is the February 27, 1914 issue of Engineering magazine which was dedicated primarily to the third Olympic class sister, Britannic. The quotation is:

*The Britannic is to carry five anchors--one 11-ton and one 9-ton bower anchor of the "Dreadnought" type, a 16-ton Hall's patent stockless anchor, a **"stream" anchor of 20 cwt., and a kedge anchor of 10 cwt.***

Olympic and Titanic carried these identical anchors at the time of their maiden voyages. In a recent research article, I believe I offered convincing evidence that the smaller kedge anchor was located on the poop deck.

We have no evidence that either of these anchors was ever deployed during any of the Olympic class ships' careers. The requirement for ships the size of the Olympic class to carry these anchors was a requirement which had become outdated. Nevertheless, like many regulations, it persisted. So these ships not only had to comply with the regulation but the anchors and their attendant equipment had to be fully functional. Equipment had to be available and procedures had to be in place to deploy and recover these anchors. The stream anchor on the forecastle could be easily deployed with one of the cargo derricks on the foremast. The deployment of the kedge anchor on the poop deck has remained a mystery because there are no derrick or crane structures evident in the area where the kedge anchor is stowed which could be used to deploy it. Figure 1 shows the kedge anchor of Titanic stowed against the aft railing and its proximity to the flagstaff.

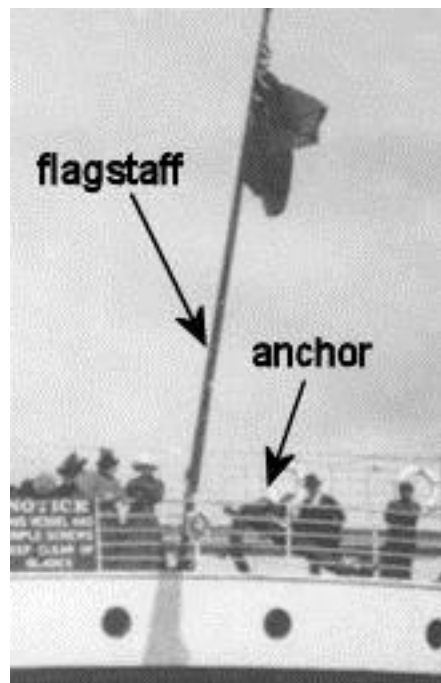

Figure 1

This article will examine a procedure which *could* be used to deploy the poop deck kedge anchor. Other procedures are certainly possible but I believe the procedure which will be described here is both possible and plausible. It will be up to the reader to decide for himself if he believes it is indeed likely.

Before outlining the anchor deployment procedures we will examine the anchor itself and the location and method of its stowage. The Trotman patent anchor was unique in that the arms pivoted on a hinge on the body of the anchor. Figure 2 is the original patent drawing of this type of anchor.

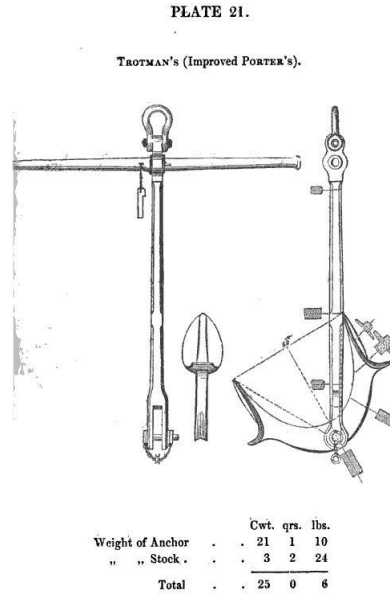

Figure 2

Figure 3 is a scale drawing of the kedge anchor mounted to the poop deck railing just to starboard of the flagstaff. The drawing view is looking from inboard toward outboard.



Figure 3

Figure 4 shows the same area of the poop deck in a plan view.

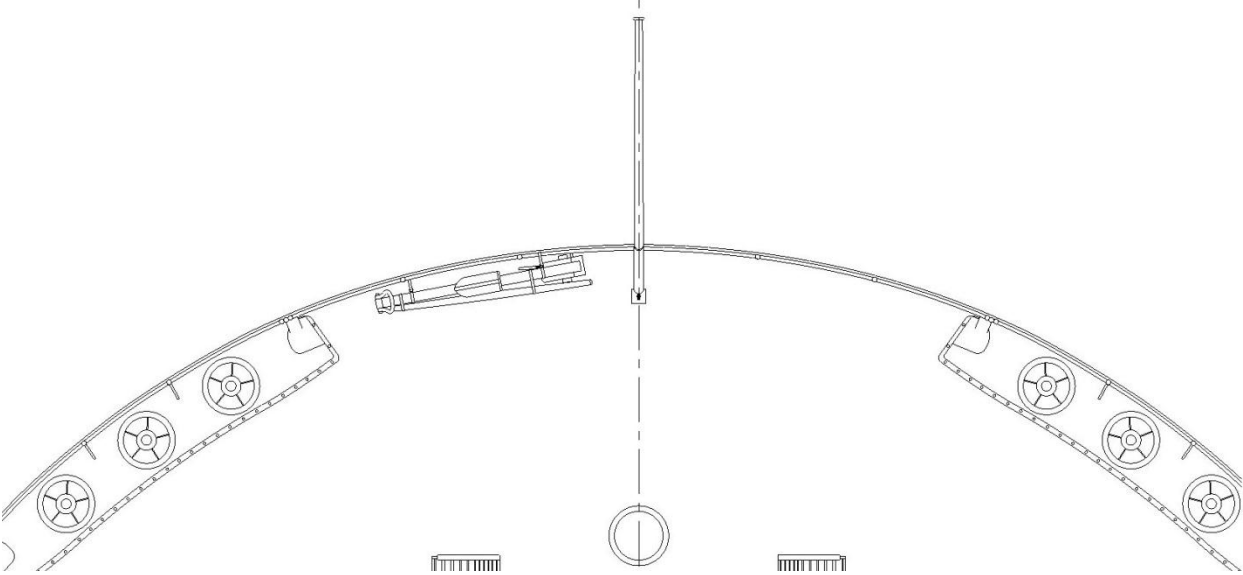

Figure 4

Now that I have illustrated the position and mounting of the kedge anchor, I will propose my theory of how it could have been raised over the railing and moved outboard. It is important to note that the kedge anchor was mounted to a section of railing which was not removable. Therefore, it had to be lifted to clear the railing which was 42 inches high. To briefly summarize my theory, I believe that the flagstaff was converted for use as a crane to deploy the anchor. In the explanation of this theory I will use scale drawings to illustrate, in a step by step manner, the individual procedures. I will primarily try to let the drawings explain the procedures. This will help keep the text to a minimum.

**1. The flagstaff in its normal position** - Figure 5 is a photo taken from inboard of Olympic's flagstaff.



Figure 5

The most important feature of the flagstaff was the gooseneck fitting near the deck. With this type of fitting, the flagstaff is able to rotate in both the x plane parallel to the deck and the y plane perpendicular to the deck. During normal use, the flagstaff is oriented directly aft so that it can be clamped and secured to the aft railing. Figure 6 shows Olympic with her flagstaff elevated to vertical confirming the ability of the flagstaff to move. Figure 7 show a drawing of the flagstaff in its normal position clamped to the aft railing.

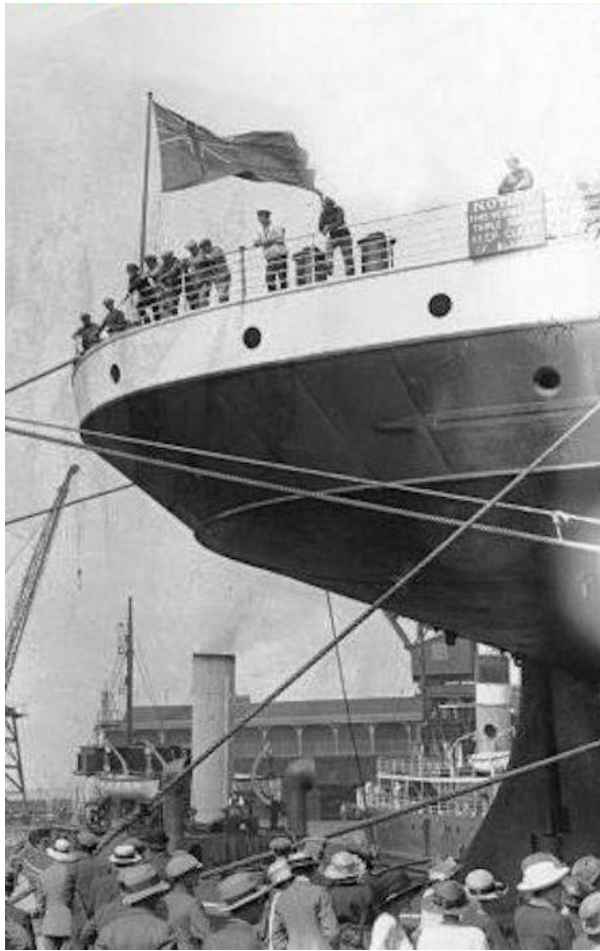

Figure 6



Figure 7

**2. The flagstaff is unclamped from the railing and rotated forward-** Figure 8 illustrates this procedure. To prepare the flagstaff for use as a crane to handle the kedge anchor, it is unclamped from the aft railing and rotated forward. In this procedure, the flagstaff is supported off the deck by a crutch.

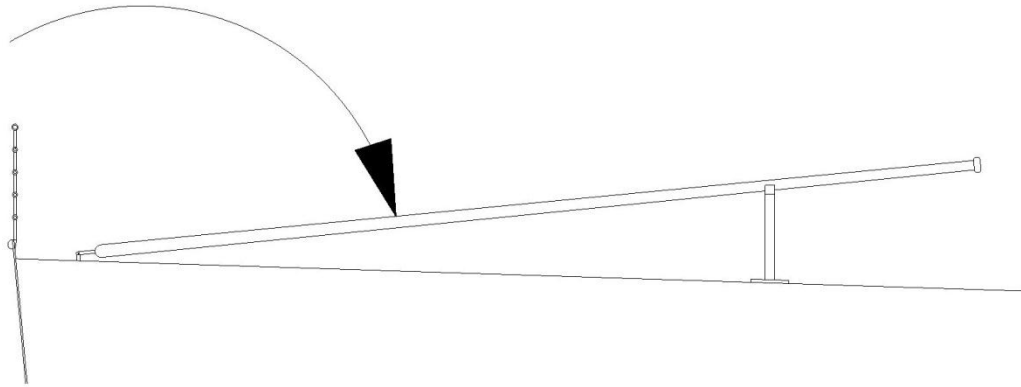

Figure 8

**3. Bands are clamped to the flagstaff –** Figure 9 illustrates this procedure. Several specialized function bands are fastened at different locations on the flagstaff. Location marks for the bands could be engraved into the flagstaff. When fully closed, the bands fit on the flagstaff at only one location because the flagstaff is tapered.

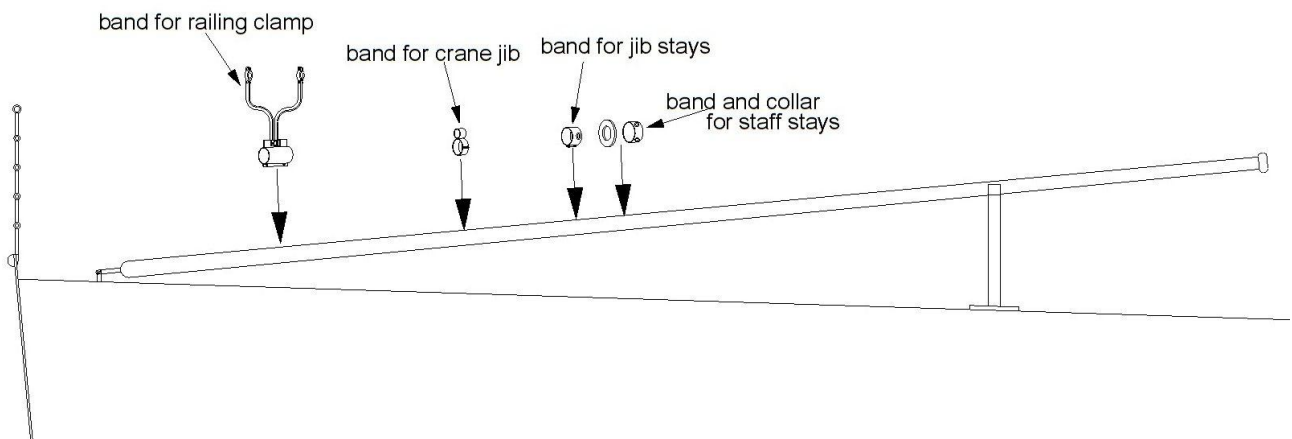

Figure 9

**4. Jib and jib stays rigged-** The jib and fixed stays to it are rigged to the bands previously rigged to the flagstaff. All blocks, tackle and lines are now attached. The jib and jib stays will be shown in the next figure where the staff is elevated to its working position. The jib and jib stays are shown in figures 10 and 11.

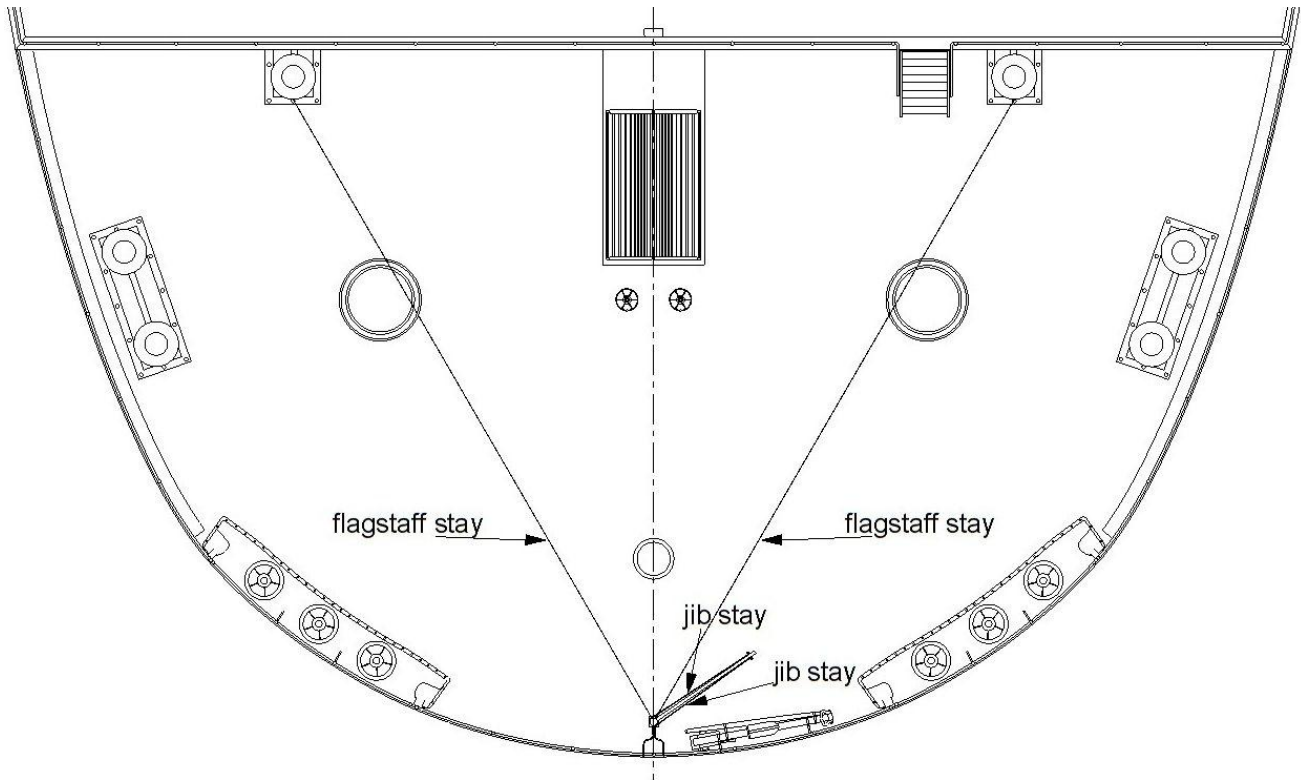

Figure 10

**5. Flagstaff elevated to vertical and stayed to aft railing (Figure 11)-**

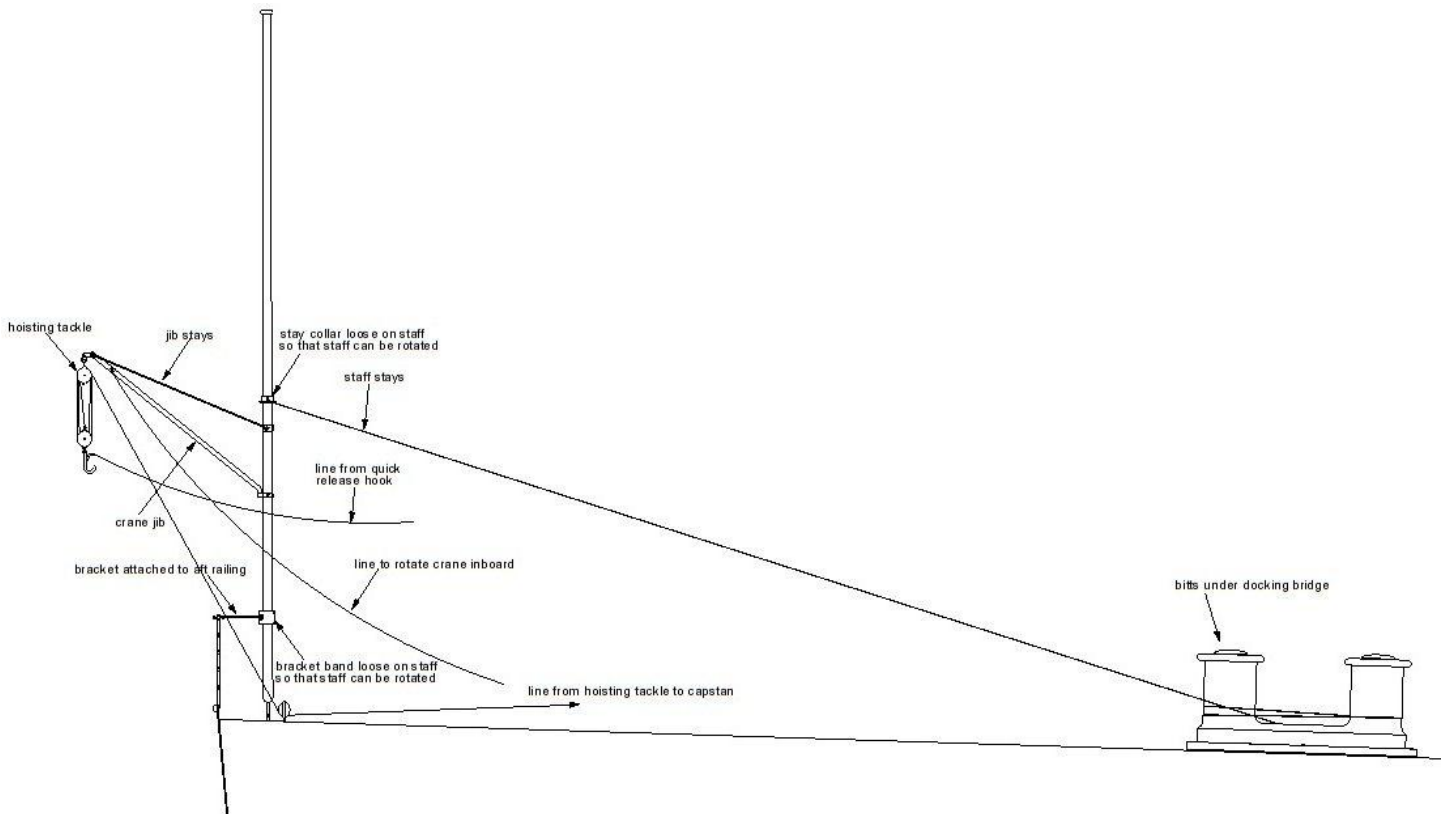

Figure 11

With all the rigging completed, the flagstaff is elevated to its vertical working position. In this position, the flagstaff is able to rotate from inboard to outboard. Two wire stays from the flagstaff are belayed to the each of the bollards under the docking bridge. The aft facing stay bracket is attached to the aft railing. The flagstaff is now stayed at three points for stability. The modified flagstaff is now ready to deploy the kedge anchor.

**6. Hoisting tackle attached to anchor located at anchor mid-body-** Figure 12 shows the hoisting tackle attached to the anchor prior to unfastening it from the aft railing. The tackle is hauled taut to prevent the anchor from falling against the railing or falling to the deck.

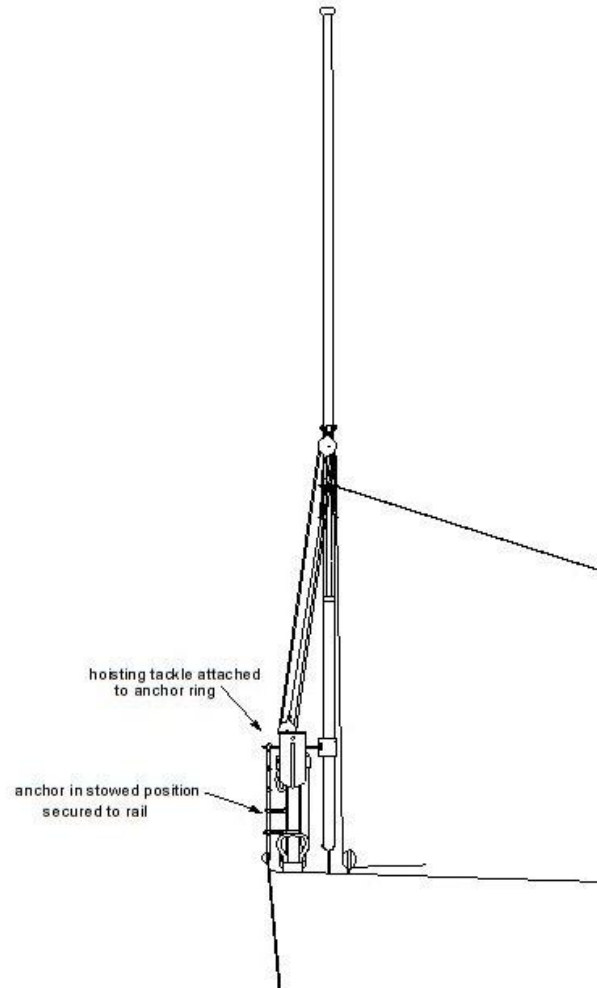

Figure 12

**7. Anchor is raised and swung inboard-** Figure 13 shows the anchor swung inboard so that the anchor stock can be fastened to the anchor. The anchor cable is attached to the anchor and is belayed to the nearest bollard.



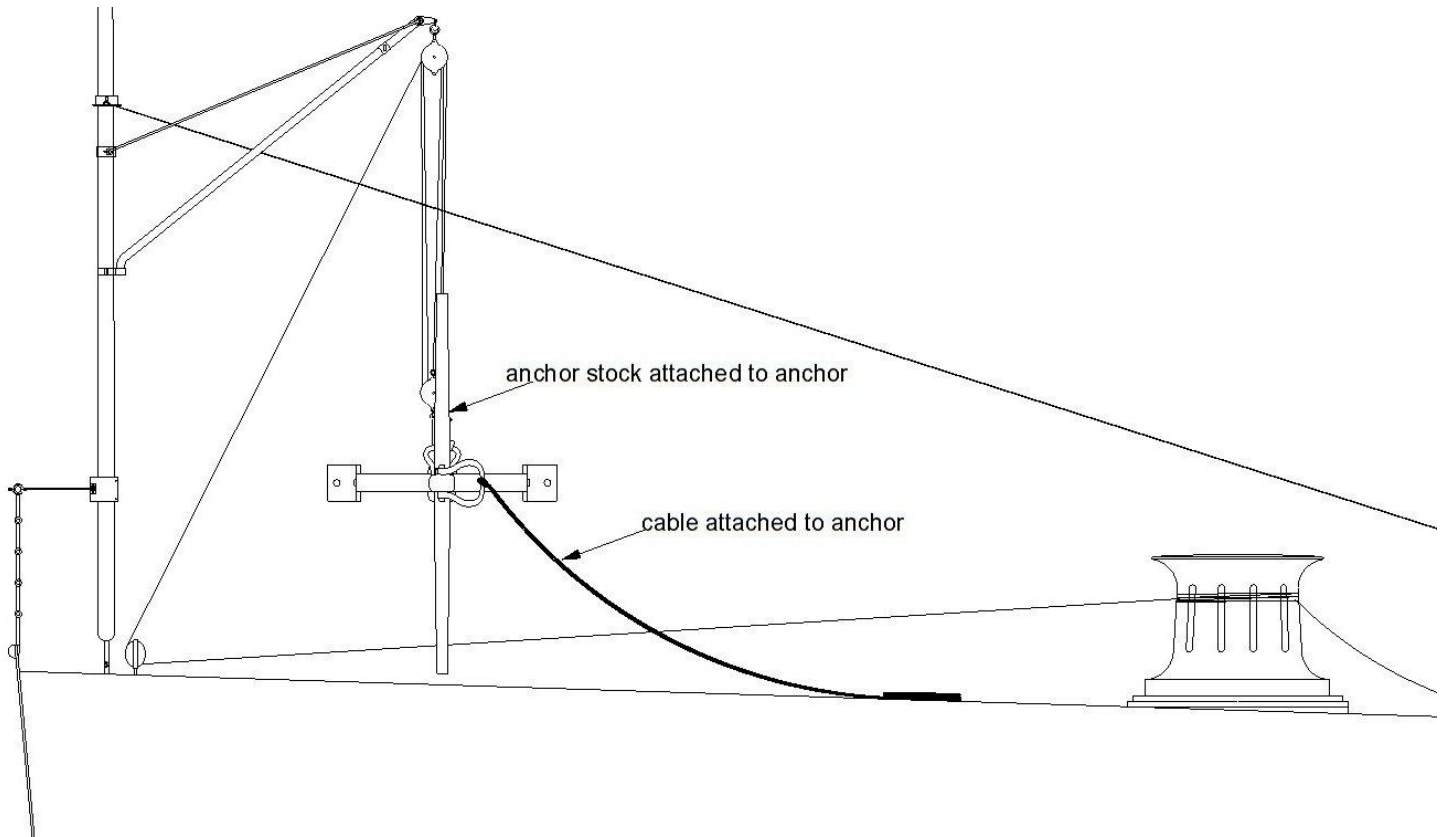

Figure 13

**8. Anchor is raised to clear railing and swung outboard (Figure 14) –**

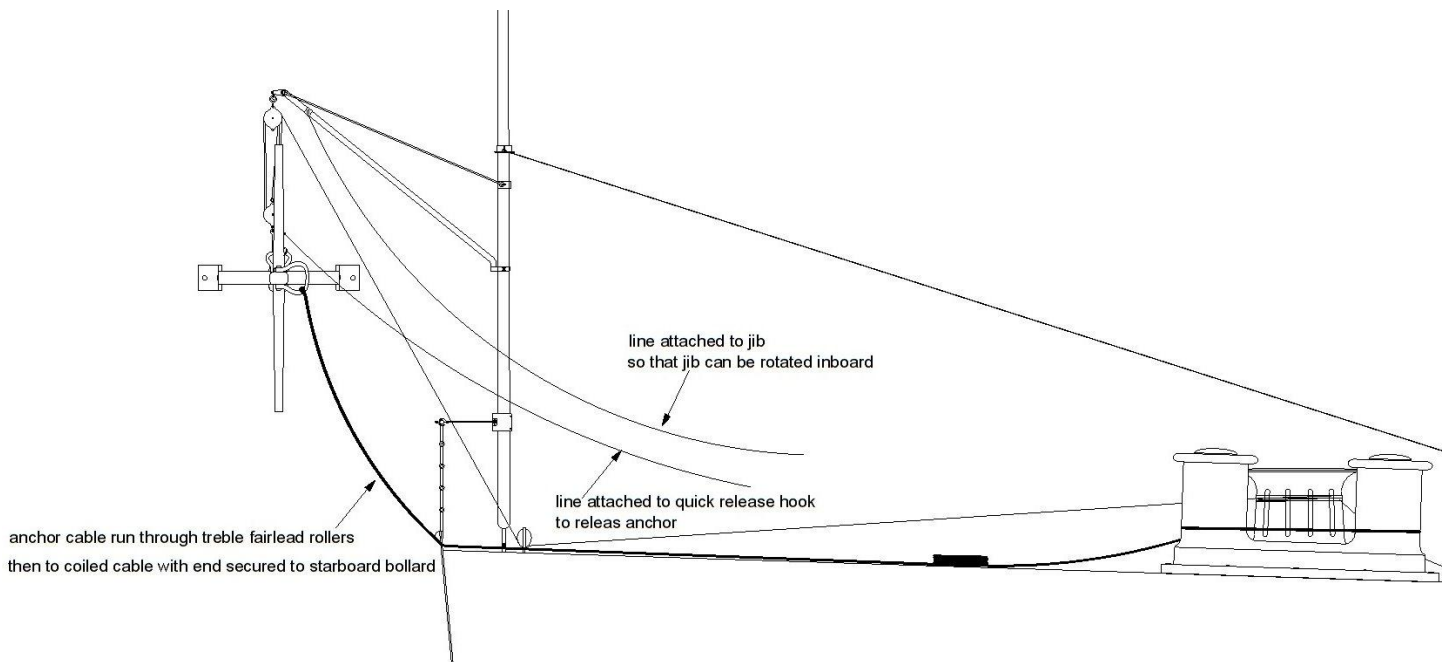

Figure 14

Figure 14 shows that the anchor has to be raised enough so that the stock clears the railing. It is then rotated outboard by crew members pushing the suspended anchor outboard and clear of the ship.

### 9. Anchor is released (Figure 15)-

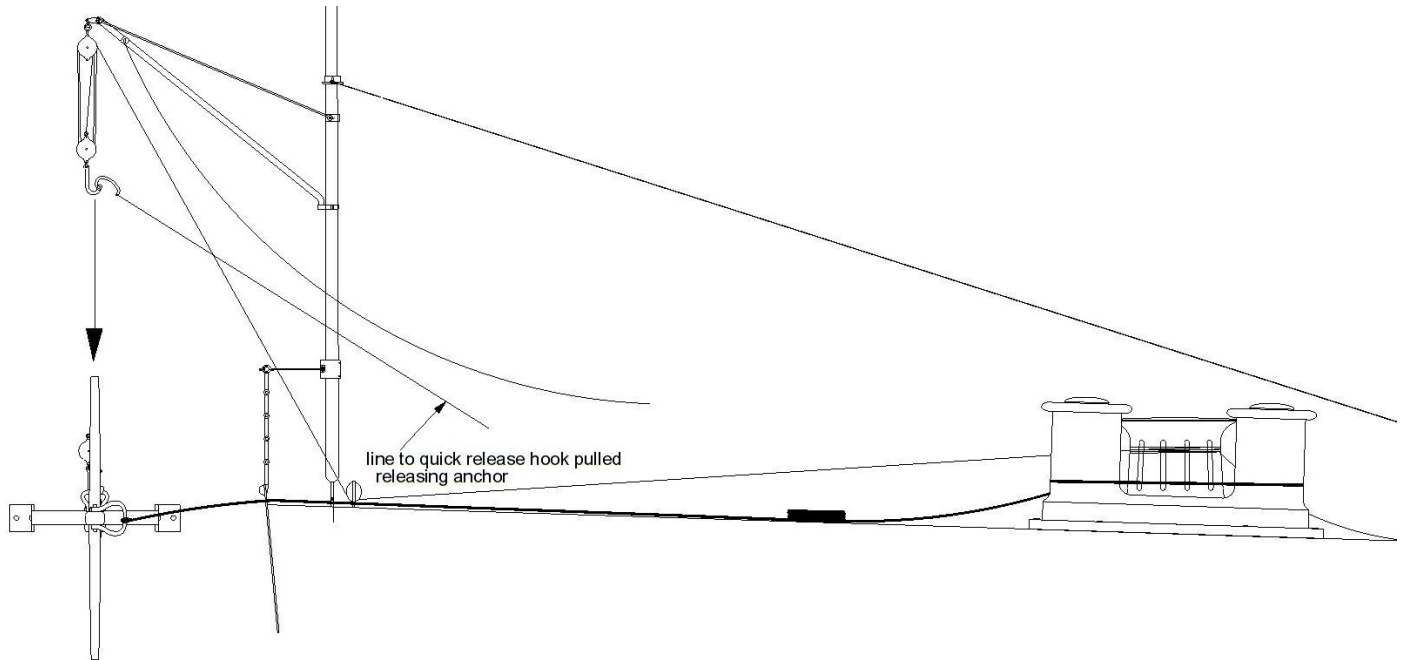

Figure 15

Figure 15 shows the anchor rotated outboard. A line to the quick release hook on the hoisting tackle is pulled, releasing the anchor.

Recovery procedures will not be discussed in depth. Briefly, the anchor cable is hauled in by the nearest capstan. When it has been hoisted near, but not touching the hull, a crewman is lowered on a painter's seat down to the anchor. The crewman reattaches the hoisting tackle to the anchor. The anchor is then fully raised outboard of the ship. Then the crane is rotated inboard. The deploying procedures would then be accomplished in reverse order to stow the anchor and return the flagstaff to its normal functional position.

There is no record of either of the auxiliary anchors being deployed. The procedure for deploying the kedge anchor was never discovered to have been recorded. Absent this information, the purpose of this article has been to propose a plausible method for its deployment. The same kind of procedures used for this anchor would have been very similar to those used to launch and recover the large center anchor on the forecastle. Unlike this procedure, the large forecastle anchor had a large, permanent crane dedicated for its use. Once the flagstaff was converted in this method the crew would have been very familiar with the procedures necessary to deploy the anchor. Unless and until some documentation of deployment procedures for the kedge anchor are uncovered, the procedures proposed here will have to suffice as a plausible alternative.

